



STATE OF NORTH CAROLINA
DEPARTMENT OF TRANSPORTATION

JOSH STEIN
GOVERNOR

DANIEL H. JOHNSON
SECRETARY

March 13, 2026

NOTICE TO PROSPECTIVE BIDDERS

Subject: Addendum No. 1
Division Eleven

Contract No.: DK00450
WBS: 2026CPT.11.06.20061
County: Avery County
Location: 13 Sections of Secondary Routes in Avery County
Type of Work: Resurfacing, Shoulder Reconstruction, and Pavement Markings
Bid Opening: March 19, 2026

To Whom It May Concern:

Reference is made to the plans furnished to you on this project. The following revisions have been made to the Plans.

Sheet No.	Revision
14	Added New Sheet - Manhole Adjustment Detail

Please add the above listed Pages in your proposal. This revision is reflected in the Plans currently on the Division 11 Letting Page.

Sincerely,

Bethany Elmore, PE
Division Contract Engineer

- CC: Michael Poe, PE, Division Engineer
- Brandon Whitaker, PE, Deputy Division Engineer
- Ivan Dishman, PE, Division Construction Engineer
- Matthew Evans, PE, Division Maintenance Engineer
- Ramie Shaw, PE, Division Program Development Engineer
- David Wayne, PE, District Engineer
- Scott Pipes, PLS, Resident Engineer

Mailing Address:
NC DEPT. OF TRANSPORTATION
DIVISION ELEVEN
P. O. BOX 250
NORTH WILKESBORO, NC 28659

Telephone: (336) 903-9101
Website: www.ncdot.org

Location:
NC DEPT. OF TRANSPORTATION
DIVISION ELEVEN
801 STATESVILLE RD
NORTH WILKESBORO, NC 28659

GENERAL NOTES:

1. USE RAPID SET DYED CONCRETE WITH A MINIMUM COMPRESSIVE STRENGTH OF 4000 PSI.
2. REMOVE ALL FAULTY EXISTING BRICKWORK AND REPLACE WITH NEW BRICK MASONRY.
3. SHEER CUT RECTANGULAR EXCAVATION FOR THE ADJUSTMENT ON ALL SIDES. NO OVERSAW CUTS ALLOWED IN CORNERS.
4. FILL AREA BELOW 8" DEPTH WITH 78M OR NO. 57 CLEAN STONE.
5. MIX MORTAR TO NCDOT SPECIFICATIONS.
6. MORTAR JOINTS 1/2" +/- 1/8"

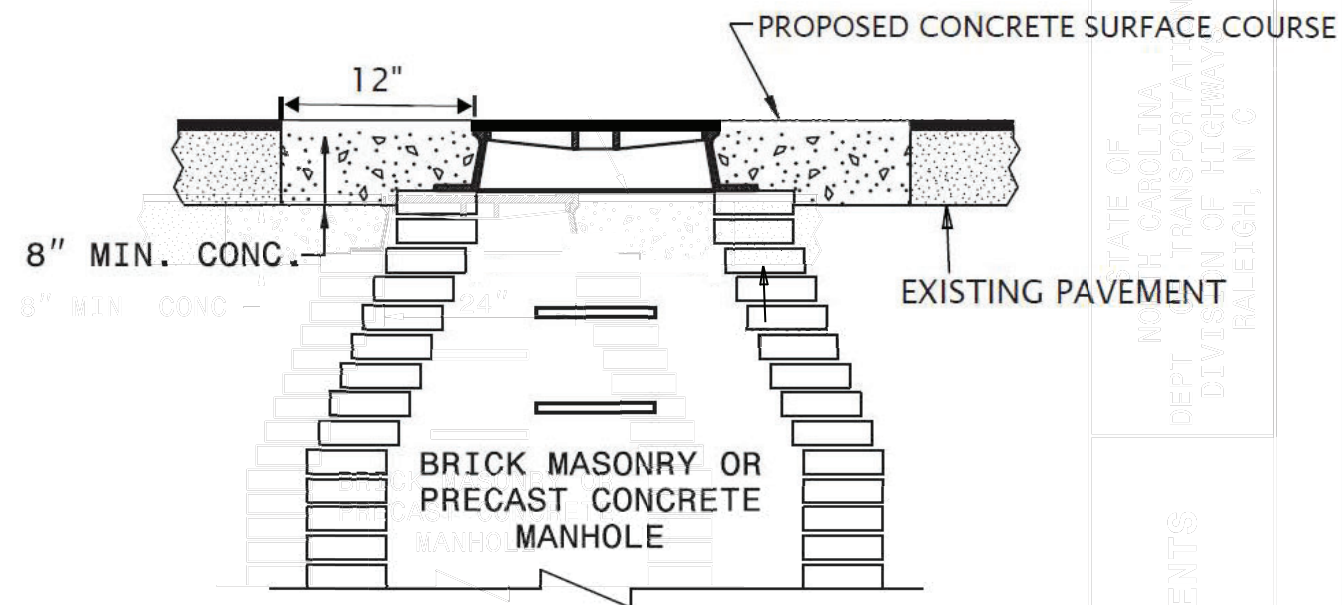

MANHOLE CONCRETE ENCASEMENT

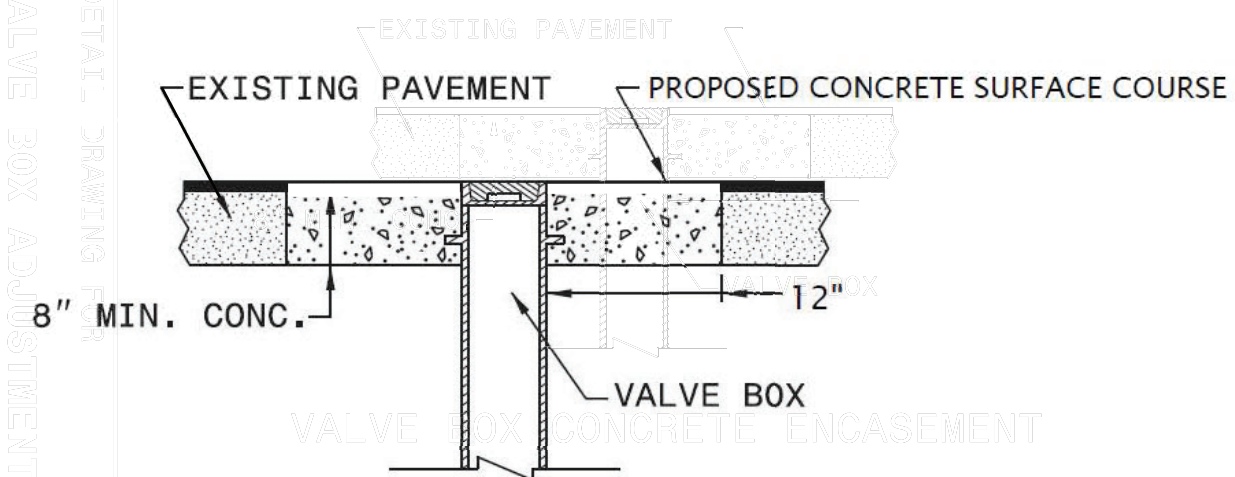

VALVE BOX CONCRETE ENCASEMENT

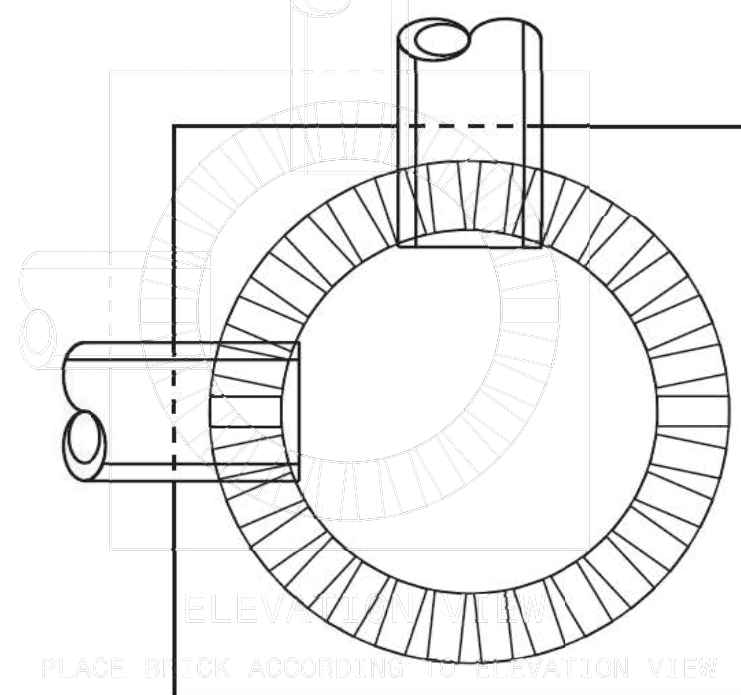

ELEVATION VIEW

PLACE BRICK ACCORDING TO ELEVATION VIEW

SHEET 1 OF 1
840D55

SHEET 1 OF 1
840D55

REVISIONS

24-JAN-2016 13:31 C:\Users\yokjmmel\Desktop\DETAIL_PSHS\Microstation Files\MH_Valve_Adjust_2015.dgn

8/17/99

NCDOT
 DEPT. OF TRANSPORTATION
 DIVISION OF HIGHWAYS
 RALEIGH, N.C.

ENGLISH DETAIL DRAWING FOR
 MANHOLE AND VALVE BOX ADJUSTMENTS

STATE OF NORTH CAROLINA
 DEPT. OF TRANSPORTATION
 DIVISION OF HIGHWAYS
 RALEIGH, N.C.

ENGLISH DETAIL DRAWING FOR
 MANHOLE AND VALVE BOX ADJUSTMENTS